



Hydrogen Peroxide Gas Sensor H2O2/CB-5000

H2O2 Gas Sensor in Compact Housing

Applications

- Discontinuous Measurement
- Sterilization Process
- Disinfection monitoring

Measurement

| | |
|--|-----------------------------------|
| Operation Principle | 3-Electrode Electrochemical |
| Nominal Range | 0 - 5000 ppm |
| Maximum Overload | 10000 ppm |
| Inboard Filter | - |
| Output Signal | 25 ± 5 nA/ppm |
| Resolution (Electronics dependent) | < 2 ppm |
| T90 Response Time | < 60 s |
| Typical Baseline Range (pure air, 20°C) | 0.0 ppm to 80.0 ppm ¹⁾ |
| Maximum Zero Shift (+20°C to +40°C) | N.D. |
| Repeatability | < 2 % of signal |
| Output Linearity | Linear |
| Gain (Only applies to 4-Electrode sensors) | - |

1) Fresh sensors with bias need 24 - 72 h for stabilization of the baseline.

Performance data recorded at 20 – 25 °C, 30 - 50% RH, 900 - 1100 mbar

For further information about usage of Membrapor sensors, see application note [MEM1](#). The data contained in this document is for guidance only. Membrapor AG accepts no liability for any consequential losses, injury or damage resulting from the use of this document or from any omissions or errors herein. Customers should test under their own conditions to ensure that the sensors are suitable for their own requirements.



Hydrogen Peroxide Gas Sensor H2O2/CB-5000

Electrical

| | |
|------------------------------|----------------------|
| Rec. Load Resistor | 10 - 33 Ω |
| Bias (V_Sens-V_Ref) | +50 mV ²⁾ |
| Conformity to RoHS directive | RoHS Compliance |

2) Recommended bias voltage changed in December 2021: From +300 mV to +50mV.

Environmental

| | |
|-------------------------|--------------------------------|
| Relative Humidity Range | 15 % to 90 % RH non-condensing |
| Temperature Range | -20 °C to 50 °C |
| Pressure Range | Atmospheric |
| Pressure Coefficient | N.D. |
| Humidity Effect | None |

Lifetime

| | |
|--|---------------------------------|
| Expected Operation Life | 2 years in air |
| Expected Long Term Output Drift in air | < 2 % signal loss per month |
| Filter Life | not applicable |
| Storage Life | 6 months in container |
| Rec. Storage Temperature | 5°C - 20°C |
| Warranty Period | 12 months from date of dispatch |

Performance data recorded at 20 – 25 °C, 30 - 50% RH, 900 - 1100 mbar

For further information about usage of Membrapor sensors, see application note [MEM1](#). The data contained in this document is for guidance only. Membrapor AG accepts no liability for any consequential losses, injury or damage resulting from the use of this document or from any omissions or errors herein. Customers should test under their own conditions to ensure that the sensors are suitable for their own requirements.



Hydrogen Peroxide Gas Sensor H2O2/CB-5000

Compact-Size Outline Dimensions

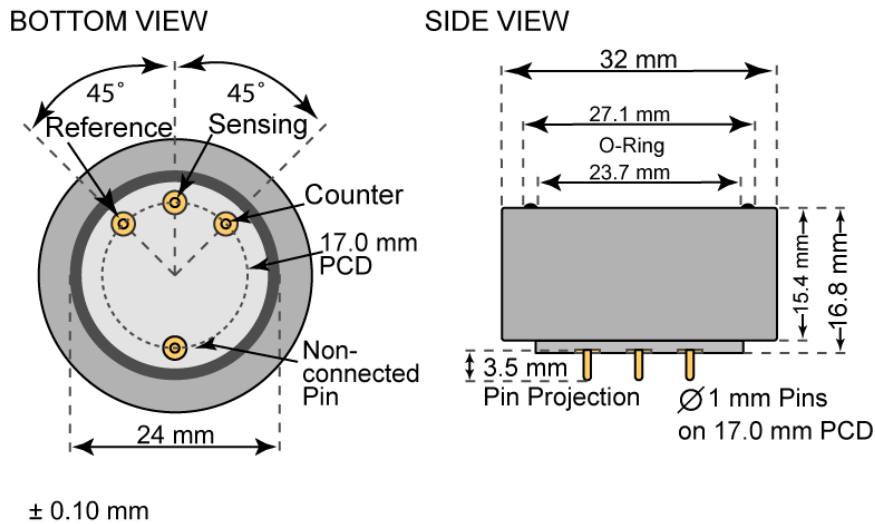

Mechanical

| | |
|------------------|---------------|
| Weight | 13 g |
| Orientation | Any |
| Housing material | Polycarbonate |

Performance data recorded at 20 – 25 °C, 30 - 50% RH, 900 - 1100 mbar

For further information about usage of Membrapor sensors, see application note [MEM1](#). The data contained in this document is for guidance only. Membrapor AG accepts no liability for any consequential losses, injury or damage resulting from the use of this document or from any omissions or errors herein. Customers should test under their own conditions to ensure that the sensors are suitable for their own requirements.



Hydrogen Peroxide Gas Sensor H2O2/CB-5000

Cross Sensitivity Data

The table below does not claim to be complete. We recommend using the target gas for calibration purposes. Using surrogate (interfering) gases can result in inaccuracies in the final calibration. Please contact Membrapor AG for further support regarding cross sensitivities.

| Interfering Gas | Cross-Sens. [%] |
|-----------------|-----------------|
| SO ₂ | 100 |

Important Notes

- The H₂O₂ gas phase concentration was determined with Raoult's law for a non-ideal system.

Performance data recorded at 20 – 25 °C, 30 - 50% RH, 900 - 1100 mbar

For further information about usage of Membrapor sensors, see application note [MEM1](#). The data contained in this document is for guidance only. Membrapor AG accepts no liability for any consequential losses, injury or damage resulting from the use of this document or from any omissions or errors herein. Customers should test under their own conditions to ensure that the sensors are suitable for their own requirements.