



## Carbon Monoxide Gas Sensor CO/MFA-500

CO Gas Sensor in Miniature Housing

### Applications

- CO Detection in CO/H<sub>2</sub>-Mixtures
- For Portable Gas Detectors

### Measurement

Operation Principle	3-Electrode Electrochemical
Nominal Range	0 - 500 ppm
Maximum Overload	1000 ppm
Inboard Filter	To remove acidic gases
Output Signal	70 ± 15 nA/ppm
Resolution (Electronics dependent)	< 1 ppm
T <sub>90</sub> Response Time	< 25 s
Typical Baseline Range (pure air, 20°C)	-6.0 ppm to 3.0 ppm
Maximum Zero Shift (+20°C to +40°C)	see Graph
Repeatability	< 2 % of signal
Output Linearity	Linear
Gain (Only applies to 4-Electrode sensors)	-

#### **Performance data recorded at 20 – 25 °C, 30 - 50% RH, 900 - 1100 mbar**

For further information about usage of Membrapor sensors, see application note [MEM1](#). The data contained in this document is for guidance only. Membrapor AG accepts no liability for any consequential losses, injury or damage resulting from the use of this document or from any omissions or errors herein. Customers should test under their own conditions to ensure that the sensors are suitable for their own requirements.



### Carbon Monoxide Gas Sensor CO/MFA-500

#### Electrical

Rec. Load Resistor	10 - 33 $\Omega$
Bias (V_Sens-V_Ref)	not recommended
Conformity to RoHS directive	RoHS Compliance

#### Environmental

Relative Humidity Range	15 % to 90 % RH non-condensing
Temperature Range	-40 °C to 50 °C
Pressure Range	Atmospheric
Pressure Coefficient	N.D.
Humidity Effect	None

#### Lifetime

Expected Operation Life	3 years in air
Expected Long Term Output Drift in air	< 2 % signal loss per month
Filter Life	N.D.
Storage Life	6 months in container
Rec. Storage Temperature	5°C - 20°C
Warranty Period	12 months from date of dispatch

#### **Performance data recorded at 20 – 25 °C, 30 - 50% RH, 900 - 1100 mbar**

For further information about usage of Membrapor sensors, see application note [MEM1](#). The data contained in this document is for guidance only. Membrapor AG accepts no liability for any consequential losses, injury or damage resulting from the use of this document or from any omissions or errors herein. Customers should test under their own conditions to ensure that the sensors are suitable for their own requirements.



### Carbon Monoxide Gas Sensor CO/MFA-500

#### Miniature-Size Outline Dimensions

BOTTOM VIEW

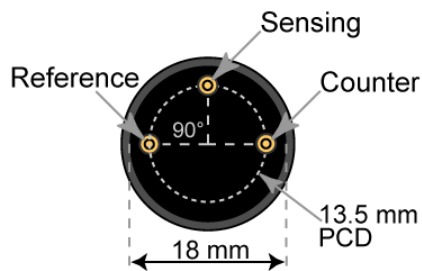

SIDE VIEW

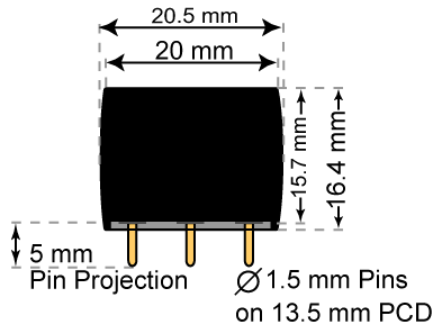

± 0.10 mm

#### Mechanical

Weight	5.5 g
Orientation	Any
Housing material	Polycarbonate

#### Performance data recorded at 20 – 25 °C, 30 - 50% RH, 900 - 1100 mbar

For further information about usage of Membrapor sensors, see application note [MEM1](#). The data contained in this document is for guidance only. Membrapor AG accepts no liability for any consequential losses, injury or damage resulting from the use of this document or from any omissions or errors herein. Customers should test under their own conditions to ensure that the sensors are suitable for their own requirements.



## Carbon Monoxide Gas Sensor CO/MFA-500

### Cross Sensitivity Data

The table below does not claim to be complete. We recommend using the target gas for calibration purposes. Using surrogate (interfering) gases can result in inaccuracies in the final calibration. Please contact Membrapor AG for further support regarding cross sensitivities.

Interfering Gas	Cross-Sens. [%]
Aromatic Hydrocarbons	N.D.
C <sub>2</sub> H <sub>4</sub>	< 5
H <sub>2</sub>	< 15
H <sub>2</sub> S	0
NO	0
NO <sub>2</sub>	0
SO <sub>2</sub>	0

#### **Performance data recorded at 20 – 25 °C, 30 - 50% RH, 900 - 1100 mbar**

For further information about usage of Membrapor sensors, see application note [MEM1](#). The data contained in this document is for guidance only. Membrapor AG accepts no liability for any consequential losses, injury or damage resulting from the use of this document or from any omissions or errors herein. Customers should test under their own conditions to ensure that the sensors are suitable for their own requirements.



### Carbon Monoxide Gas Sensor CO/MFA-500

#### Temperature dependence

The output of an electrochemical sensor varies with temperature. The graphs below show the temperature-dependent variation of baseline and sensitivity, respectively. The results shown here are raw data (batch average) without any post-processing steps. The sensitivity and baseline are referenced to the signal at 20°C (reference point).

Please note: It is highly recommended to acquire the temperature dependence curves with the whole instrument. The sampling system, the humidity, the electronics and the interaction between the electronics and the sensor have a significant impact on the temperature dependence of the final measurement reading.

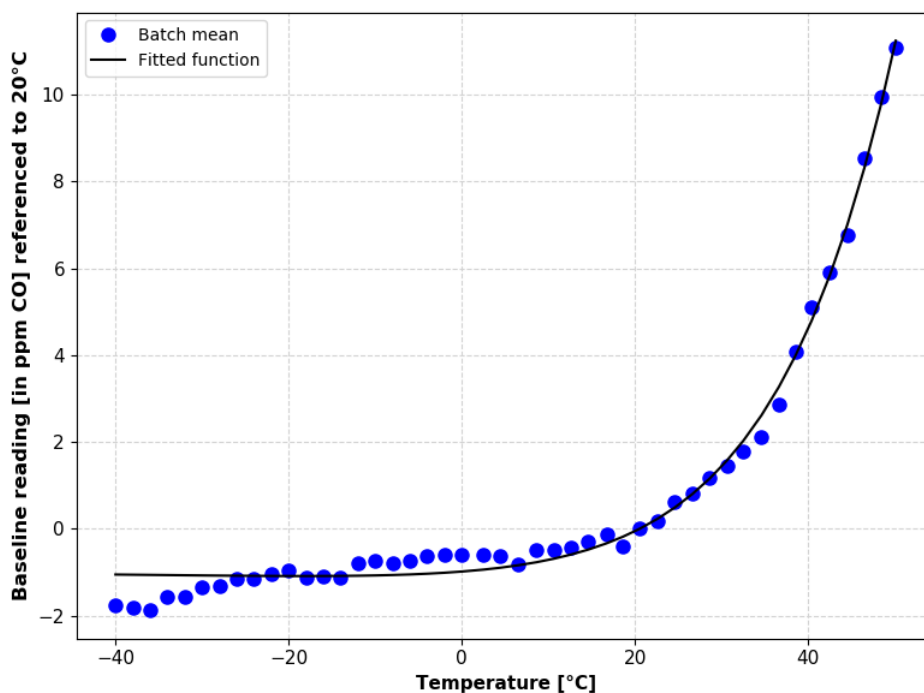

Baseline shifted with respect to reference point at 20°C.

#### **Performance data recorded at 20 – 25 °C, 30 - 50% RH, 900 - 1100 mbar**

For further information about usage of Membrapor sensors, see application note [MEM1](#). The data contained in this document is for guidance only. Membrapor AG accepts no liability for any consequential losses, injury or damage resulting from the use of this document or from any omissions or errors herein. Customers should test under their own conditions to ensure that the sensors are suitable for their own requirements.